

Technical Specifications and User Guide for the GDCO Detector

The GDCO detector is a device designed to detect the presence of carbon monoxide in the air. Its main advantages are easy operation and application, small size and high mechanical resistance. The body is made of duralumin. The detector comprises a sensitive heated semiconductor sensor with extended life. The GDCO device is characterized by increased sensor selectivity for carbon monoxide. Exceeding the preset concentration is indicated optically by two indicator lights and acoustically by a built-in siren. The device can be controlled (switched on) by a rocker switch.

The GD51 detector has fixed built-in batteries to power the device in operation. Charging the internal batteries is possible with a common AC adapter. The charging process is automatically controlled by the device electronics. The device is intended for use in normal environment as a simple portable indicator of the CO presence.

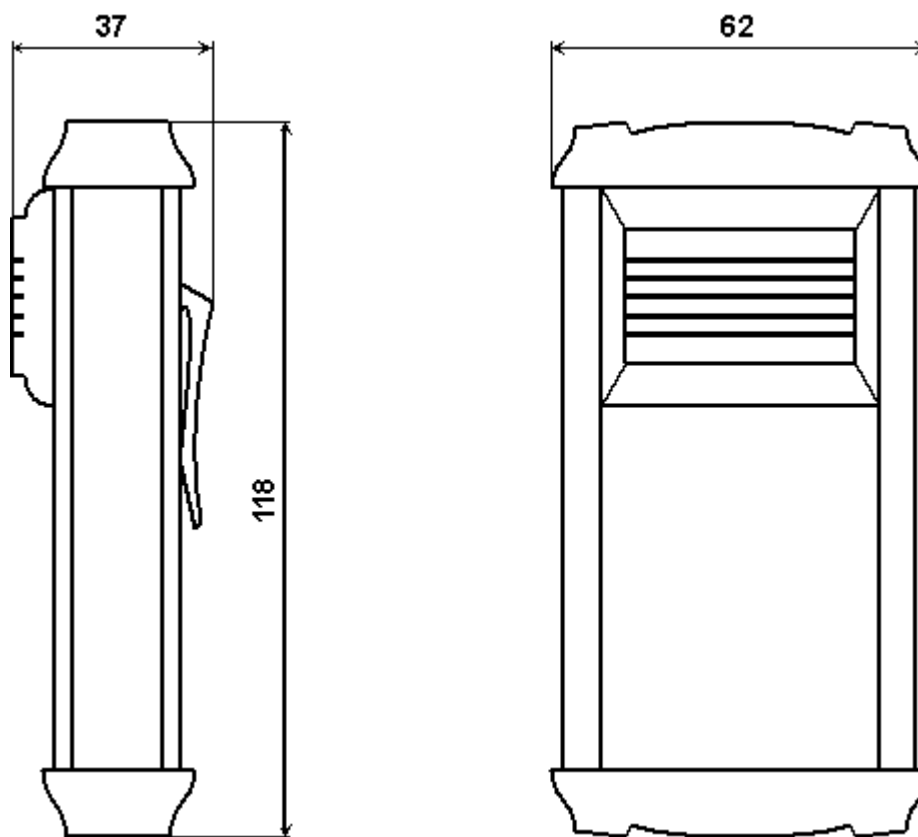

Technical Specifications:

Mechanical dimensions:	118 x 62 x 37 mm
Weight:	approx. 200 g
Detected gas:	carbon monoxide
Max. detected concentration:	240 ppm
Detection instability:	+/- 20 ppm / 3 months
Sensor lifetime:	more than 3 years in normal atmosphere
Warm-up time:	max. 1 minute
Time to steady the signal T(90):	max. 1 minute
Recovery time:	max. 1 minute
Operating time when fully charged:	approx. 25 hours
Charging duration:	max. 12 hours
Charging adapter voltage:	6 V (or 9 or 12 V)
Operating environment:	AB4 without a danger of explosion
Humidity:	20 to 90 % RV
Storage environment:	10 to 30 °C, 20 to 80 % RV
Max. storage life:	1 year
Designed according to:	ČSN EN 45544
The tests performed in the laboratory:	AZL No. 1025

Operating the GD51 Device

1. Switching On

The GDCO device is switched on by a rocker switch on top of the unit. After switching on all three indicator lights turn on and you will hear 3 beeps. After the initial control signaling only a green "ON/Bat" indicator light remains on and the device is ready for operation. In case the sensor wasn't ventilated enough after the last measurements, the detector may indicate the presence of gas after switching on (see below). In this case leave the detector in clean the air for several minutes - the signalling should drop to zero - the sensor is ventilated.

2. Gas Detection

When in operation, the "ON/Bat" indicator light is on and you will hear one short beep once a minute.

After placing the detector into the monitored atmosphere, it needs to be left for more than 1 minute to stabilize. The detector will indicate the measured concentration through the combination of shining or flashing "Alarm 1" and "Alarm 2" indicator lights. Exceeding the concentration is indicated according to the following table:

concentration ppm	Alarm 1	Alarm 2
up to 30	off	off
30	flashing	off
60	on	off
90	off	flashing
120	flashing	flashing
150	on	flashing
180	off	on
210	flashing	on
240	on	on

When the "Alarm 2" indicator light is on or flashing, it is accompanied by an acoustic signal. The siren beeps continuously ("Alarm 2" is on) or intermittently ("Alarm 2" flashes).

If the device has indicated any gas concentration, leave it in clean air before switching off to ventilate, so that the signal drops to zero, and then switch the device off.

3. Power Supply

The GD51 device is powered from fixed battery cells firmly built into the body of the device. When measuring, the device continuously monitors the state of its batteries. If a voltage drop is detected, the detector will indicate the battery status by three consecutive short beeps. Initially, the signaling appears once a minute, with a further voltage drop the signal frequency increases to 4 times per minute.

If the detector starts signalling a drop in the battery voltage regularly, it is necessary to recharge the batteries (see below).

4. Battery Charging

Battery charging is accomplished by connecting the AC adapter to the connector on the bottom of the device. A charging adapter with an output voltage of 6 to 12 V can be used. We recommend a charging adapter with the voltage of 6 V. The batteries can be charged in two ways:

- a) When switched off, connect the device to the AC adapter. A minimum trickle current flows through the batteries. In this way the device can be charged indefinitely.
- b) When you switch the device on and then you connect it to the AC adapter, a new recharge cycle starts. The batteries are charged until full. The charging duration is signaled by switching of the "ON/Bat" indicator light from green to red (when using a 6 V AC adapter). When an adapter with a higher output voltage is used, the "ON/Bat" indicator light switches between green and red with a

period of 8 seconds. The charging failure is signaled by quickly alternating green and red color of the "ON/Bat" indicator light.

After the charging is finished, only the green "ON/Bat" indicator light is on and the current flowing into the battery changes into a trickle current.

5. Carrying the device

To carry the device, you can use its clip-on holder, by which means the device can be attached e.g. on your belt etc. To lift off the holder you need to lift the upper part labeled "1" with your finger a little, and then lift off the holder (see picture on the holder).

6. Detector Inspection and Calibration

According to the frequency of use, we recommend checking the GD51 detector once every 3 months (if used very often - permanently) or once a year (less frequent use) using a calibration gas mixture. The detector with charged batteries should be switched on at least 15 minutes before being checked. Apply the sensor to a calibration gas with a CO concentration in the range from 100 to 200 ppm. The device should show a corresponding concentration with a signaling resolution of 1 division.

Also a smoke stick can be used for testing the gas detection ability of the device. After igniting the smoke stick, extinguish the flame and let the stick smolder. Hold the detector in the smoke rising from the stick for about 10 to 20 seconds, so that the wider part with the sensor is immersed into the smoke. The detector should respond to the CO presence in the smoke from incomplete combustion. After finishing the test, the smoke stick should be extinguished thoroughly and the detector should be left for at least 15 minutes in clean air to ventilate. We do not recommend leaving the detector in the smoke over a long period of time.

7. Limitations of Application

The GDCO detector is designed to detect CO presence in the atmosphere. It should be not located in flue gas or used for a gas mixture analysis. In the presence of some interfering gases in the atmosphere, the signalization may be biased. A cross-sensitivity to hydrogen and acetylene is known, less so to nitrogen oxide and ethanol. Interfering gases act additively on the sensor.

The GD51 device is not intended for use in locations designated as Zone 0, Zone 1 or Zone 2. The device must not be used in places with high humidity, and a penetration of water droplets or other chemicals into the gas sensor must be prevented. The device is designed for normal non-aggressive environment. The GD51 device is not intended for use in locations designated as Zone 0, Zone 1 or Zone 2. The device must not be used in places with high humidity, and a penetration of water droplets or other chemicals into the gas sensor must be prevented. The device is designed for normal non-aggressive environment.

Accessories

- Charging AC adapter
- Smoke sticks

Service

Any repairs or technical assistance can be provided at:

J.T.O. System, s.r.o., 1. máje 823, 756 61 Rožnov pod Radhoštěm, CZ, tel. +420 571 843 343

If the device is taken out of service, it must be disposed in environmentally friendly way - i.e. brought to the designated collection point for disposal of electronic waste.